

The Role of the Internet of Things (IoT) in Smart Cities: A Systematic Literature Review in the Fields of Lighting and Energy

 Yasin Aktaş

Researcher, yasinaktas_23@hotmail.com, [10.5281/zenodo.20521849](https://zenodo.org/doi/10.5281/zenodo.20521849)

Received: Mar 25, 2026

Accepted: Jun 01, 2026

Published: Jun 05, 2026

Abstract: This study examines the role of Internet of Things (IoT) technologies in the context of smart cities, particularly in the fields of lighting and energy management, using a systematic literature review method. IoT strengthens data-driven decision-making mechanisms in urban management by integrating processes of data collection, transmission, and analysis through sensors and smart devices. Within the scope of the research, academic studies published between 2020 and 2025 were analyzed using the databases Google Scholar, DergiPark, and YÖK Thesis Center. The findings were evaluated through thematic analysis and examined under two main themes: smart lighting and energy efficiency. The results indicate that smart lighting systems provide energy savings, enhance user comfort, and offer remote control capabilities through sensors and automation technologies. However, limitations such as sensor accuracy, system integration challenges, and data security issues are noteworthy. In the field of energy management, IoT-based smart grids and energy monitoring systems have been found to optimize energy consumption, reduce costs, and support sustainability. Nevertheless, high installation costs, technical infrastructure requirements, and cybersecurity risks hinder the widespread adoption of these systems. In conclusion, the study reveals that IoT technologies offer significant opportunities in terms of efficiency and sustainability in public services. However, in order to fully realize this potential, technical, economic, and administrative challenges must be addressed through comprehensive and integrated policy approaches.

Keyword: Internet of Things (IoT), Smart Cities, Smart Lighting Systems, Energy Management, Data Security

JEL Classification: L94

1. Introduction

As cities grow and expand spatially, the need for smart and innovative solutions to increase productivity, enhance operational efficiency, and reduce management costs has become increasingly evident (Hammi et al., 2018). In line with this need, the Internet of Things (IoT), which

entered the literature with the development of web-based technologies in the 1990s, has emerged as a fundamental paradigm enabling physical objects to establish an autonomous communication network.

Within the IoT ecosystem, various components such as vehicles, buildings, and industrial devices operate in an integrated manner through processes of data collection, processing, and sharing, thereby creating a more holistic digital infrastructure. The increasing rate of urbanization and the growing complexity of infrastructure requirements have transformed IoT-based smart city solutions from a preference into a necessity. Technologies developed in this context provide significant operational efficiency in areas such as traffic management, energy, lighting, and environmental pollution control (Ismail et al., 2025).

This transformation process, driven by the integration of IoT into urban structures, brings about fundamental changes in the design, planning, and management processes of cities. In response to urban challenges such as increasing traffic congestion, environmental pollution, energy consumption, and security issues, IoT offers data-driven and real-time solutions, enabling a more effective management approach. The analysis of data obtained through sensors and smart devices contributes to the efficient use of resources, the improvement of public services, and the enhancement of quality of life. In this context, particularly in the energy sector, IoT-based smart grids enable balanced management of consumption and facilitate the integration of renewable energy sources, thereby increasing system reliability and sustainability (Rehan, 2023).

In addition, within the IoT ecosystem, lighting systems are optimized through smart control mechanisms. These systems, which can be remotely managed via sensors and intelligent interfaces, dynamically adjust lighting levels according to user needs and environmental conditions. In particular, through the integration of daylight and occupancy sensors, artificial lighting is automatically reduced or turned off when natural light is sufficient. In this way, energy efficiency is enhanced and consumption is significantly reduced (Topal & Konakoğlu, 2025).

In this study, the effects of Internet of Things (IoT) technologies on public services within the context of smart cities are examined through a systematic literature review, particularly focusing on smart lighting and energy efficiency. The main objective of the study is to analyze the contributions of IoT applications in these areas within a holistic framework and to reveal the current state as well as the structural challenges encountered. The findings obtained from the relevant literature were evaluated through thematic classification. In this evaluation, not only technological benefits but also economic, technical, and administrative limitations were discussed. Thus, the study aims both to contribute to the academic literature and to provide a guiding framework for policymakers and practitioners.

2. Conceptual Framework

The Internet of Things (IoT) is a dynamic ecosystem in which devices, machines, and objects in the physical world are not only interconnected but are also capable of sensing their environment, sharing data, and acting with collective intelligence (Reklewska, 2023). First introduced in 1999 by Kevin Ashton, this concept enables internet-connected devices to communicate with one another, generate and exchange data, and perform specific tasks. Through the integration of sensors, machines, and other physical objects over networks, it becomes possible to monitor and control environmental data. In this respect, IoT represents a system capable of simultaneously performing functions such as sensing, communication, and data processing. It has also contributed to the transformation of the internet from merely a communication network into a broader ecosystem encompassing smart devices and embedded systems (Yıldız, 2021).

The foundation of this ecosystem is formed by a network structure based on standardized communication protocols. While the internet functions as the convergence point of these protocols, the number of devices capable of connecting, communicating, and sensing environmental conditions based on the data they collect is steadily increasing. These devices not only gather data but can also establish their own network structures and generate new information from the data they obtain. This situation positions IoT as an integral and continuously expanding component of the internet (Reklewska, 2023; Öz, 2020).

The real strength of IoT lies in its ability to collect large volumes of data in real time through numerous sensors and to process this data into meaningful information. This capability significantly enhances data-driven decision-making processes, particularly in smart city applications. In smart cities, the data collection and processing process consists of four main stages: data acquisition through sensors, transmission of data to cloud systems via communication technologies such as Wi-Fi and 5G, systematic storage of data, and finally, analysis using advanced techniques such as machine learning (Ismail et al., 2025).

Figure 1 illustrates the integrated process among data collection, transmission, storage, analysis, and decision support mechanisms in IoT-based smart city systems (Ismail et al., 2025).

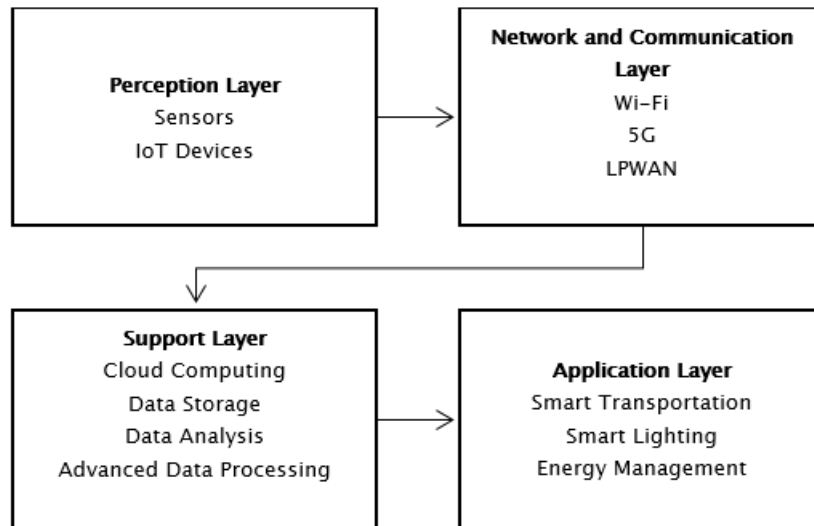

Figure 1. IoT Data Processing Process in Smart Cities

Through this integrated structure, raw data is transformed into meaningful and processable information, and decision-making mechanisms in urban management are optimized using real-time data. In this respect, IoT stands out as a critical technology that provides innovative solutions across various sectors and supports a data-driven management approach. However, this rapid development process also brings along various technical and administrative challenges (Ismail et al., 2025).

Among these challenges, issues of security and privacy are of primary concern. With the widespread adoption of IoT-based smart city applications, the increasing number of internet-connected devices and the storage of data in cloud environments significantly elevate cybersecurity risks. In this context, ensuring data privacy, developing secure communication protocols, and strengthening authentication and authorization mechanisms have become critical requirements. Additionally, conducting comprehensive risk analyses against potential threats and establishing effective security management systems are essential. Therefore, although IoT-based smart cities have the potential to improve quality of life, it is imperative to carefully address security and privacy dimensions to ensure their sustainable and secure implementation (Babahanoğlu et al., 2020; Öz et al., 2019).

3. Research and Methodology

This study was conducted using the systematic literature review approach, which is one of the qualitative research methods, in order to examine the effects of Internet of Things (IoT) technologies on public services. A systematic literature review is a research methodology that

enables the systematic, transparent, and reproducible examination and synthesis of existing studies within the framework of a specific research question (Yıldız, 2022).

During the research process, a review protocol was developed to ensure the transparency and reproducibility of the study. Within this scope, the main objective of the research and the research questions were defined, appropriate databases were selected, and inclusion and exclusion criteria were determined in advance. In the study, a comprehensive literature review was conducted using the databases Google Scholar, DergiPark, and the YÖK Thesis Center.

In the literature review process, the keywords “Internet of Things,” “IoT and Smart Cities,” “IoT-Based Smart Lighting,” and “Energy Management/Energy Efficiency” were searched in both Turkish and English using AND/OR operators. To ensure the relevance and timeliness of the review, studies published between 2020 and 2025 were considered.

Additionally, only studies with full-text access and academic merit (peer-reviewed journals, theses, and scientific publications) were included in the evaluation.

The study selection process was carried out in stages in accordance with the systematic literature review approach. In the first stage, the titles and abstracts of the studies were examined; in the second stage, the full texts of the selected studies were evaluated. Duplicate studies and those not directly related to the research topic were excluded from the analysis. This process is consistent with the structured review approach recommended in systematic review studies (Yıldız, 2022).

The selected studies were further examined in accordance with quality assessment criteria. In this context, evaluations were conducted by considering the methodological appropriateness, data reliability, and research scope of the studies. To minimize bias and enhance the reliability of the findings, the predetermined criteria were applied systematically throughout the research process. During the data extraction phase, information such as the author, publication year, methodology, research area, and key findings was systematically collected from the included studies. The obtained data were then analyzed using the thematic analysis method. In this process, an open coding approach was adopted, and common themes highlighted in the literature were identified. As a result of the thematic analysis, the impacts of IoT applications on public services were grouped under two main themes: smart lighting and energy efficiency. Within each theme, the opportunities offered by IoT-based systems (such as increased efficiency, resource optimization, and decision-support mechanisms) and the challenges encountered (such as high costs, infrastructure deficiencies, and data security issues) were comparatively evaluated.

This study aims to reveal the efficiency gains provided by IoT-based systems in public services and to analyze the limitations encountered in this process. In this context, the following research questions have been addressed:

- What types of operational benefits do IoT applications provide in the fields of lighting and energy management?
- What are the main economic and technical barriers to the widespread adoption of these technologies?

Figure 2 explains the impact of Internet of Things (IoT) technologies on smart city applications through three main components. The model presents a holistic structure that demonstrates the effects of IoT on urban systems not directly, but through specific application areas. In this context, the first stage addresses the impacts of IoT technologies on lighting and energy systems. In the second stage, the contributions of these application areas to cities' operational efficiency, resource utilization, and sustainability performance are evaluated. Thus, the model systematically explains the indirect effects of IoT within the smart city ecosystem and reveals the interactions between different components.

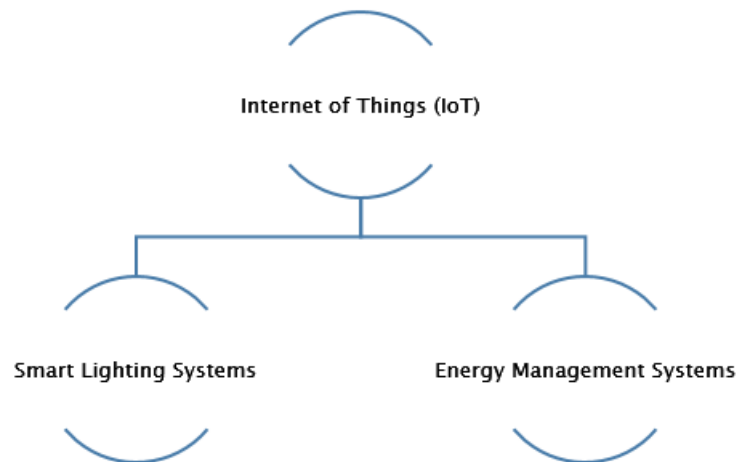

Figure 2. Research Model

4. Findings and Literature Review

In this section, the findings obtained from the systematic literature review were evaluated using the thematic analysis method. The reviewed studies were classified under two main Themes—smart lighting and energy Efficiency—in order to reveal the role of IoT technologies in smart city applications. Within each theme, both the operational advantages provided by IoT applications and the technical and economic limitations were addressed together.

4.1. IoT-Based Smart Lighting

The simultaneous development of LED technology and the Internet of Things (IoT) has enabled lighting systems to be remotely controlled without the need for wiring, allowing users to create scenario-based automations and transforming residential lighting into an intelligent system. Next-generation IoT-based lighting solutions integrate each lighting point into cloud infrastructures through wireless communication technologies. In this way, centralized, flexible, and user-oriented management is achieved via mobile and web applications. This transformation not only provides ease of installation and cost advantages but also turns lighting infrastructure into a multifunctional digital platform.

In addition, Visible Light Communication (VLC) and Visible Light Positioning (VLP) technologies enable LED-based lighting systems to perform functions such as data transmission and indoor positioning.

The ability of LEDs to function similarly to Li-Fi by transmitting data through light and enabling this data to be received via photodetectors provides a significant advantage, particularly in indoor environments where GPS is insufficient. However, these developments also bring critical issues such as data security and user privacy. Therefore, ensuring secure data transmission and maintaining system integrity have become fundamental requirements in IoT-based lighting systems (Erkin & Onaygil, n.d.). In this context, relevant studies in the literature have been systematically evaluated and summarized in Table 1.

Table 1. Summary of IoT-Based Smart Lighting Studies

Author (Year)	Application Area	IoT Technology Used	Benefits Provided	Limitations
Sur (2020)	Smart home lighting systems	IoT-based motion sensors, light sensors, smart bulbs, automatic control systems, internet-connected lighting management	Automatic control of lighting, reduction of unnecessary energy consumption, energy savings, increased user comfort, reduction of light pollution	Dependence on sensor accuracy, installation cost, need for system integration, performance variation depending on user habits
Khoa et al. (2020)	Smart home and smart lighting systems	ESP8266 microcontroller, sensors, Wi-Fi, WebServer, mobile applications, SHA-256 security algorithm,	Real-time monitoring and control, energy savings, remote management, automated lighting, secure data	Data security risks, cloud security issues, system complexity, vulnerability to

Author (Year)	Application Area	IoT Technology Used	Benefits Provided	Limitations
		cloud and database integration	transmission, increased user comfort	cyberattacks of IoT devices
Dankan Gowda et al. (2021)	Indoor and outdoor lighting systems in smart cities	IoT-based sensors, ZigBee, BLE, Wi-Fi, DALI, PLC, 6LoWPAN communication protocols	Remote control, automated lighting management, user comfort, real-time monitoring	Protocol incompatibility, system integration difficulties, security vulnerabilities
Avcı (2022)	Smart home and smart lighting systems	Wireless sensor networks, IoT devices, M2M communication, cloud systems, mobile application-based control	Remote control, energy savings, increased comfort, automated lighting management	Cybersecurity risks, data privacy issues, user-related vulnerabilities
Şensoy (2022)	Smart building lighting systems	IoT sensors, communication protocols such as Wi-Fi/Bluetooth, web-based control interfaces, automation systems	Automatic lighting based on environmental data, remote control, energy savings, user comfort	Incompatibility between different devices and protocols, lack of standards, system integration cost
Gaeed (2023)	Smart lighting systems	ESP32, Wi-Fi, IoT cloud platforms, sensor-based control systems	Remote lighting control, energy savings, automated management	System integration requirements, hardware dependency
Altunkaya (2024)	Street, park, and intercity road lighting systems	SCADA systems, Arduino Mega2560, LDR sensor, camera (image processing), web & mobile applications (ASP.NET, Flutter), MySQL database	Energy savings, reduction of unnecessary lighting, fault detection, remote monitoring and control, increased security	Installation and system complexity, need for hardware and software integration
İpek & Çöp (2025)	Smart lighting systems	ESP8266-based IoT platform, Wi-Fi communication, mobile and web-based control interfaces, cloud integration	Remote control, energy efficiency, modular structure, real-time control	Hardware dependency, system integration requirements
Yılmaz & Aydın (2025)	Smart lighting systems	IoT sensors, smart lighting control systems, automation software	Automatic control of lighting systems, energy savings, increased user comfort and efficiency	High installation cost, system integration challenges, performance

Author (Year)	Application Area	IoT Technology Used	Benefits Provided	Limitations
				variation depending on user behavior
Yusubov (2025)	Smart home and lighting systems	Sensors, IoT-based automation, wireless networks	Automatic control, energy savings, user comfort	Security vulnerabilities, data breach risks, system integrity issues

When the studies presented in Table 1 are examined, it is evident that IoT-based smart lighting systems largely rely on sensor technologies, wireless communication protocols, and automation systems. The literature generally agrees that these systems provide energy savings, optimize lighting processes, and enhance user comfort. In particular, smart lighting solutions that operate based on environmental data (such as light levels and motion detection) contribute to more sustainable energy use by reducing unnecessary energy consumption. In addition, features such as remote control, automated lighting management, and mobile application integration increase the flexibility and ease of use of these systems. However, the reviewed studies also reveal several significant limitations of smart lighting systems. Dependence on sensor accuracy, limitations in wireless communication infrastructure, and initial hardware costs are among the main factors affecting their widespread adoption. Furthermore, technical and operational issues such as data security, user-related errors, device incompatibility, and the need for system integration can directly impact system performance. Incompatibility between different protocols and devices, in particular, makes it difficult to manage systems holistically, especially in large-scale applications.

4.2. IoT-Based Energy Efficiency

Traditional electrical systems are based on centralized generation facilities such as fossil fuels or hydroelectric power and deliver energy to end users through a one-way flow. This structure leads to uncertainties in demand forecasting due to the inability to obtain real-time data from users, often requiring energy supply to exceed actual demand. Moreover, since the detection and resolution of faults in the grid generally depend on manual interventions, the system's flexibility and response speed remain limited. Today, with the widespread adoption of renewable energy sources, users have evolved from being mere consumers to also becoming producers. This transformation has necessitated the evolution of energy systems into more flexible, monitorable, and data-driven structures. In this context, smart grids-enabled by IoT technologies and advanced communication infrastructures-make it possible to monitor and optimize energy production, distribution, and consumption in real time. These systems, which allow for bidirectional energy and data flow, enable instant fault detection and support self-healing capabilities within the

system (Ismail et al., 2025). In this regard, relevant studies in the literature have been systematically evaluated and summarized in Table 2.

Table 2. Summary of IoT-Based Energy Efficiency Studies

Author (Year)	Application Area	IoT Technology Used	Benefits Provided	Limitations
Sur (2020)	Smart home lighting systems	IoT-based motion sensors, light sensors, smart bulbs, automatic control systems, internet-connected lighting management	Automatic control of lighting, reduction of unnecessary energy consumption, energy savings, increased user comfort, reduction of light pollution	Dependence on sensor accuracy, installation cost, need for system integration, performance variation depending on user habits
Khoa et al. (2020)	Smart home and smart lighting systems	ESP8266 microcontroller, sensors, Wi-Fi, WebServer, mobile applications, SHA-256 security algorithm, cloud and database integration	Real-time monitoring and control, energy savings, remote management, automated lighting, secure data transmission, increased user comfort	Data security risks, cloud security issues, system complexity, vulnerability to cyberattacks of IoT devices
Dankan Gowda et al. (2021)	Indoor and outdoor lighting systems in smart cities	IoT-based sensors, ZigBee, BLE, Wi-Fi, DALI, PLC, 6LoWPAN communication protocols	Remote control, automated lighting management, user comfort, real-time monitoring	Protocol incompatibility, system integration difficulties, security vulnerabilities
Avcı (2022)	Smart home and smart lighting systems	Wireless sensor networks, IoT devices, M2M communication, cloud systems, mobile application-based control	Remote control, energy savings, increased comfort, automated lighting management	Cybersecurity risks, data privacy issues, user-related vulnerabilities
Şensoy (2022)	Smart building lighting systems	IoT sensors, communication protocols such as Wi-Fi/Bluetooth, web-based control interfaces, automation systems	Automatic lighting based on environmental data, remote control, energy savings, user comfort	Incompatibility between different devices and protocols, lack of standards, system integration cost
Gaeed (2023)	Smart lighting systems	ESP32, Wi-Fi, IoT cloud platforms, sensor-based control systems	Remote lighting control, energy savings, automated management	System integration requirements, hardware dependency

Author (Year)	Application Area	IoT Technology Used	Benefits Provided	Limitations
Altunkaya (2024)	Street, park, and intercity road lighting systems	SCADA systems, Arduino Mega2560, LDR sensor, camera (image processing), web & mobile applications (ASP.NET, Flutter), MySQL database	Energy savings, reduction of unnecessary lighting, fault detection, remote monitoring and control, increased security	Installation and system complexity, need for hardware and software integration
İpek & Çöp (2025)	Smart lighting systems	ESP8266-based IoT platform, Wi-Fi communication, mobile and web-based control interfaces, cloud integration	Remote control, energy efficiency, modular structure, real-time control	Hardware dependency, system integration requirements
Yılmaz & Aydın (2025)	Smart lighting systems	IoT sensors, smart lighting control systems, automation software	Automatic control of lighting systems, energy savings, increased user comfort and efficiency	High installation cost, system integration challenges, performance variation depending on user behavior
Yusubov (2025)	Smart home and lighting systems	Sensors, IoT-based automation, wireless networks	Automatic control, energy savings, user comfort	Security vulnerabilities, data breach risks, system integrity issues

When the studies presented in Table 2 are examined, it is evident that IoT-based energy management systems largely rely on real-time data monitoring, automation, and intelligent analysis mechanisms. The literature generally agrees that these systems optimize energy consumption, improve the efficiency of resource utilization, and make significant contributions to sustainability goals. In particular, through smart grid systems, building energy management, and IoT-supported automation solutions, energy production and consumption processes become more dynamic and flexible.

However, despite the gains achieved in energy efficiency, the reviewed studies also reveal several important limitations. High initial costs, technical infrastructure requirements, and system integration challenges are among the main factors limiting the widespread adoption of these technologies. Additionally, technical issues such as data security, device heterogeneity, and incompatibility between different protocols can negatively affect the sustainability and

effectiveness of these systems. In particular, big data management and cybersecurity risks stand out as critical challenges for the future development of IoT-based energy systems.

5. Discussion

When the findings are evaluated as a whole, it is evident that IoT-based applications provide significant operational efficiency in the fields of smart lighting and energy management. In particular, energy management applications appear to generate broader and more systematic impacts compared to smart lighting systems. Indeed, the literature emphasizes that IoT-based energy systems provide more direct and measurable benefits in terms of real-time monitoring, consumption optimization, and cost reduction (OECD, 2019).

When both themes are evaluated together, it is understood that IoT technologies strengthen data-driven decision-making processes, optimize resource utilization, and enhance the effectiveness of public services. These findings are consistent with international studies indicating that digitalization makes urban services more efficient, sustainable, and user-oriented (OECD, 2020). However, it is also observed that the limitations highlighted in the literature are largely similar across both themes. In particular, high initial costs, system integration challenges, deficiencies in technical infrastructure, and data security risks emerge as common problem areas in both lighting and energy systems.

In this context, data management and security issues emerge as critical factors for the sustainability of smart city applications. According to the OECD, although the volume of data generated in smart cities is rapidly increasing, the effective management, sharing, and protection of this data create significant governance challenges (OECD, 2023). This situation demonstrates that data security and privacy in IoT-based systems are not only technical issues but also managerial concerns. Furthermore, incompatibility between systems and the lack of standardization hinder the interoperability of different IoT devices and lead to the formation of data silos. OECD (2023) states that such data silos limit the effectiveness of smart city applications and make holistic urban management more difficult. In addition, insufficient attention to data security and privacy can undermine user trust, thereby negatively affecting the adoption of these technologies.

Therefore, in order to fully realize the potential offered by IoT technologies in smart cities, not only technological aspects but also economic, managerial, and legal dimensions must be addressed through a holistic approach. This finding is consistent with the literature emphasizing that the success of smart cities depends not merely on technological investments, but also on governance, integration, and human-centered policy approaches (OECD, 2020).

6. Conclusion and Policy Recommendations

This study examined the effects of IoT technologies in the context of smart cities, particularly in the areas of smart lighting and energy management, through a systematic literature review. The findings reveal that IoT-based applications make significant contributions in terms of increasing energy efficiency, optimizing operational processes, and enhancing the effectiveness of public services. However, it has also been determined that factors such as high costs, infrastructure deficiencies, data security issues, and system integration challenges constitute major barriers to the widespread adoption of these technologies.

Based on these findings, the policy recommendations developed are presented below:

- First, it is evident that data security and privacy issues are critical factors for the sustainability of IoT-based systems. Therefore, local governments should develop comprehensive data governance policies covering data collection, storage, and sharing processes, and strengthen their cybersecurity infrastructures.

- Second, high infrastructure and installation costs are among the primary factors limiting the widespread adoption of smart city applications. In this context, it is important to promote public-private partnerships, develop alternative financing models, and strengthen the financial capacity of local governments.

- Third, in order to sustain the efficiency gains provided by IoT-based systems, data-driven decision-making processes need to be institutionalized. In this regard, it is recommended to increase investments in digital infrastructure and enhance data analytics capacity within urban governance.

- Fourth, system integration issues and the lack of standardization constitute significant technical barriers that limit the effectiveness of IoT applications. Therefore, it is necessary to develop common data standards that ensure interoperability between different systems and to adopt open platform architectures.

- Finally, in order to fully utilize the potential of IoT technologies in terms of energy optimization, it is important to expand the implementation of smart grid systems and establish real-time energy monitoring mechanisms. This approach will not only enhance energy efficiency but also contribute to the goals of sustainable urban management.

In conclusion, IoT technologies play a critical role in the transformation of smart cities, and there is a need for holistic and multidimensional policy approaches to ensure their effective and sustainable implementation.

References

- Altunkaya, M. (2024). SCADA Sistemi Ve Görüntü İşleme Teknikleri Kullanarak Gerçek Zamanlı Aydınlatma Sisteminin Tasarımı (Yayınlanmamış Yüksek Lisans Tezi). Necmettin Erbakan Üniversitesi, Konya.
- Anna, R. (2021). The Importance of the Internet of Things for Smart Cities. 8th IFIP International Workshop on Artificial Intelligence for Knowledge Management (AI4KM), Jan 2021, Yokohama, Japan. https://doi.org/10.1007/978-3-030-80847-1_8
- Avcı, İ. (2022). Akıllı Evlerde IoT Teknolojileri ve Siber Güvenlik. *Avrupa Bilim ve Teknoloji Dergisi*, (34), 226– 233.
- Babahanoğlu, V., Bilici, Z., & Örselli, E. (2023). Teknolojik Devinimin Kentlere Getirmiş Olduğu Fırsat Ve Tehditler: IoT Tabanlı Akıllı Kentler Üzerinden Bir Analiz. *Journal of Academic Value Studies*, 6(3), 254–265. <https://doi.org/10.29228/javs.45352>
- Bauer, M., Sanchez, L., & Song, J. (2021). IoT-Enabled Smart Cities: Evolution and Outlook. *Sensors*, 21(13), 4511, 1–29. <https://doi.org/10.3390/s21134511>
- Dankan Gowda, V., Annepu, A., Ramesha, M., Kumar, P. K., & Singh, P. (2021). IoT Enabled Smart Lighting System for Smart Cities. *Journal of Physics: Conference Series*, 2089(1), 012037. <https://doi.org/10.1088/1742-6596/2089/1/012037>
- Erkin, E., & Onaygil, S. (t.y.). Yeni Nesil Akıllı Aydınlatma Sistemleri ve Geleceği. <https://www.emo.org.tr/>, (Erişim Tarihi: 09.04.2026).
- Gaeed, S. A. G. (2023). Intelligent Power Management Grids Based on IoT (Unpublished Master's Thesis). Ankara University, Ankara.
- Hammi, B., Khatouni, R., Zeadally, S., Fayad, A., & Khoukhi, L. (2017). Internet of Things (IoT) Technologies for Smart Cities. *IET Networks*, 7(2), 123–135.
- Ismail, A. I., Ismail, M. A. H., & Johari, S. (2025). Smart Cities Implementing IoT Applications for Security Technologies and Future Recommendations. *International Journal of Innovative Research and Scientific Studies*, 8(3), 1376–1387. <https://doi.org/10.53894/ijirss.v8i3.6802>
- İpek, E., & Çöp, M. E. (2025). IoT Cloud Tabanlı Smartled Driver. S. Neşeli, H. Terzioğlu, & S. Servi (Ed.), *Selçuk University 4th International Technology and Innovation Student Symposium* (s. 343–357), Eğitim Yayınevi.
- Khoa, T. A., Nhu, L. M. B., Son, H. H., Trong, N. M., Phuc, C. H., Phuong, N. T. H., Dung, N. V., Nam, N. H., Chau, D. S. T., & Duc, D. N. M. (2020). Designing Efficient Smart Home Management with IoT smart Lighting: A Case Study. *Wireless Communications and Mobile Computing*, 2020, 8896637. <https://doi.org/10.1155/2020/8896637>
- Kuncan, M. & Çaça, Ö. (2019). Akıllı Ev Teknolojisi için Kablosuz Akıllı Kit. *Avrupa Bilim ve Teknoloji Dergisi*, (17), 271–282.
- OECD. (2019). *Enhancing the Contribution Of Digitalisation to The Smart Cities Of the Future*. OECD Publishing.

- OECD. (2020). *Smart Cities and Inclusive Growth*. OECD Publishing.
- OECD. (2023). *Smart City data Governance: Challenges and the Way Forward*. OECD Publishing.
- Öz, S., Dindarık N., Duman, F. (2019). Schumpeteryan Girişimcilik ve 21. Yüzyıl Girişimcilik Yaklaşımları: Y Kuşağı Girişimcileri Üzerine Nitel Bir Araştırma, *opus* (13), pp. 1059–1091.
- Öz, S. (2020). Genel Teknoloji ve Dijital Dönüşüm Teorisine Giriş. Book Chapter in “Teknolojik ve Dijital Dönüşüm”, Nobel, pp. 169–192.
- Rehan, H. (2023). Internet Of Things (IoT) in Smart Cities: Enhancing Urban Living Through Technology. *Journal of Engineering and Technology*, 5(1), 1–16.
- Salih, S., Abdelazih, A., Husain, O., Motwakel, A., Elshafie, H., Sharif, M., & Hamdan, M. (2025). IoT in Urban Development: Insight into Smart City Applications, Case Studies, Changes, and Future Prospects. *PeerJ Computer Science*, 11:e2816, 1–42. <https://doi.org/10.7717/peerj-cs.2816>
- Sur, Y. (2020). BIM ve Akıllı Konut Teknolojilerinin Konut Yenileme Projelerinde Kullanımına Sürdürülebilirlik Bağlamında Yaklaşım. *Yapı Bilgi Modelleme*, 2(2), 66–78. <https://izlik.org/JA65WR34CK>
- Şensoy, M. (2022). *Akıllı Binalarda Web Teknolojilerinin Kullanımı (Yayınlanmamış Yüksek Lisans Tezi)*. Marmara Üniversitesi, İstanbul.
- Taşkesen, E., Üren, R., & Üren, S. (2023). Nesnelerin İnterneti (IoT) ve Akıllı Şebekeler: IoT Cihazlarının Akıllı Şebekelerde Kullanımı. *International Journal of Advanced Natural Sciences and Engineering Researches*, 7(4), 43–49.
- Üstün Topal, T., & Kurt Konakoğlu, S. S. (2025). Akıllı Kent Odağında Açık ve Yeşil Alan Sistemlerinde Nesnelerin İnterneti (IoT) Tabanlı Uygulamalar. M. Zencirkıran & N. Seyidoğlu Akdeniz (Ed.), *Peyzaj Mimarlığında Bilimsel Yaklaşımlar–2025* (s. 97–117). Livre de Lyon.
- Yıldız, A. (2022). Bir Araştırma Metodolojisi Olarak Sistemik Literatür Taramasına Genel Bakış. *Anadolu Üniversitesi Sosyal Bilimler Dergisi*, 22(Özel Sayı 2), 367–386. <https://doi.org/10.18037/ausbd.1227366>
- Yıldız, B. (2021). Internet of Things and Smart Cities: A Bibliometric Analysis. *Quantrade Journal of Complex Systems in Social Sciences*, 3(1), 27–44. <https://izlik.org/JA33GU85JB>
- Yılmaz, E., & Aydın, D. (2025). Akıllı Ev Sistemlerinin Enerji Tasarrufu Potansiyeli ve Geri Ödeme Süreleri Üzerine Bir Vaka Analizi. *Modular Journal*, 8(2), 470–491. <https://doi.org/10.59389/modular.1660648>
- Yusubov, F. (2025). *Akıllı Evlerde IoT Teknolojileri İçin Siber Güvenlik Tehditleri Ve Bir Çözüm Önerisi (Yayınlanmamış Yüksek lisans tezi)*. İstanbul Aydın Üniversitesi, İstanbul.